

EDC-CMA3

Home | Security | Dome Cameras | Accessories

EDC-CMA3

Corner Mount Adapter for Fastrax Wall Bracket EDC-WMB1,

Steel Metal

Art-Nr. 73155



Main Features

For corner mounting of Fastrax bracket EDC-WMB1

Rugged steel construction

Surface pre-treatment for rust protection

Power coated varnished: RAL9001

Ready for installation

Technical drawing

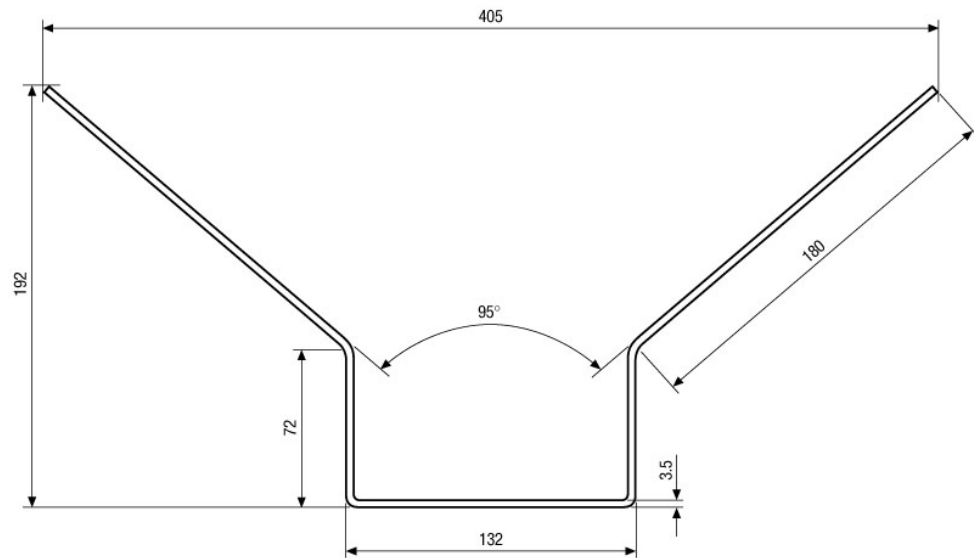

Schenkelansicht / side view

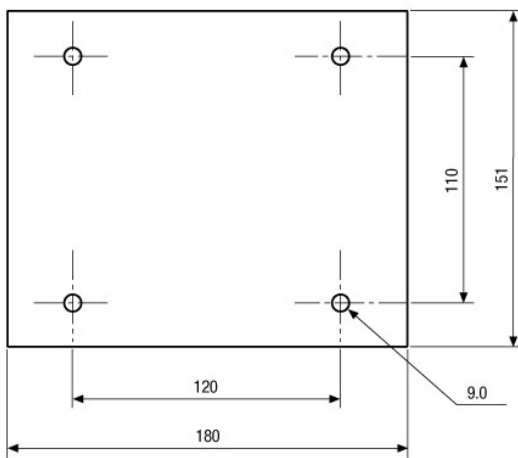

Frontansicht - Montageplatte / Front view - mounting plate

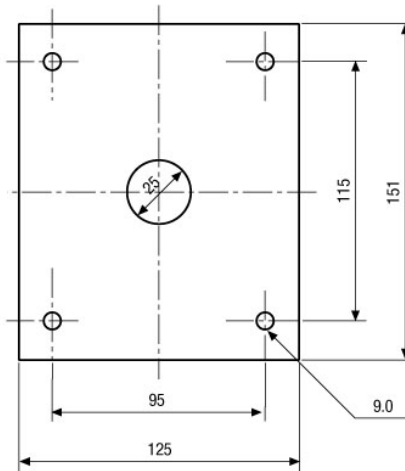

Maße/Dimensions: mm

SLD Security & Communications
The Old Forge, Ockham Lane, Ockham, Surrey GU236PH England
Phone +44.1483225633 · Fax +44.1483225634
sales@sld.co.uk · www.sld.co.uk

