

# VKC-1379B/IR316

Home | Security | Cameras | Plug & Play

VKC-1379B/IR316  
1/3" Camera, Pixim, Day&Night, 3.5-16mm, 570TVL,

WDR, IR LED, 12/24V, IP68

**Art-Nr. 92752**



## Main Features

1/3" RGB colour DPS sensor (Pixim Seawolf)

Removal IR cut filter (ICR)

Sensitivity of 0.4Lux at F1.2 (colour)

Integral varifocal lens F1.2/3.5-16mm

Powerful digital noise reduction (DNR)

Wide dynamic range (WDR): 102dB, 120dB max.

Privacy masking / Mirror function

Low speed shutter control (DSS)

80m Night observation distance (70 pcs. IR LED's)

Externally adjustable focus & zoom

Supply voltage: 12VDC or 24VAC

Bullet housing, wall mount, hidden cable routing

## Specifications

System	day&night
Video standard	PAL/NTSC selectable
Sensor size	1/3"
Imager	DPS (Pixim), CMOS, DPS Technology
Active picture elements	400,000, (H) 720 x (V) 540 (eff.)
Synchronization	internal, AC line lock, automatic switching
Signal-to-noise ratio	50dB (AGC OFF)
Gamma correction	0.45 (configuration via menu from 0.25-1.0)
Horizontal resolution	570 TVL
Sensitivity (at 50% video signal)	0,4 Lux, (colour), 0.06Lux (B&W) at F1.2 (measured)
Low speed shutter	yes, 2 ~64 Fps., ON /OFF switchable
Automatic gain control (AGC)	supplied
Digital Noise Reduction (DNR)	yes, ON/OFF switchable

# VKC-1379B/IR316

(Continuation Specifications)

<b>Flickerless function</b>	yes
<b>Mirror function</b>	horizontal, vertical, 180° rotation
<b>White balance</b>	ATW, ATW Desat, ATW extended, manual with 2000K-11000K, R/B with Red/Blue from -20 to +20
<b>Backlight compensation</b>	no
<b>Wide Dynamic Range (WDR)</b>	yes
<b>Aperture Correction (APC)</b>	horizontal and vertical
<b>Brightness</b>	selectable
<b>Sharpness correction</b>	selectable
<b>IR cut filter</b>	switchable
<b>Video outputs</b>	composite (CVBS)
<b>Lens type</b>	varifocal
<b>Lens</b>	F1.2/3.5 ~16mm
<b>Focal length</b>	3,5 mm - 16 mm
<b>PTZ support</b>	yes
<b>Digital zoom</b>	2 ~12x, D-PTZ support
<b>Horizontal angle of view</b>	70° - 17,5°
<b>Iris control</b>	DC
<b>Focus control</b>	manual
<b>MOD (Minimum object distance)</b>	0,5 m
<b>Filter screw size</b>	not available
<b>Illumination</b>	infrared, 70x LED's 850nm. Due to an integrated light sensor the LED illumination will be switched ON/OFF, depending on environmental illumination conditions
<b>Illumination range</b>	approx. 80m (at a good light reflexion and 40% Videosignal)
<b>Menu languages</b>	English
<b>OSD function control</b>	modes (presets), WDR, day&night, shutter control, white balance, brightness, DNR, sharpness, H/V flip (mirror picture), Rotation, colour intensity, iris: DC/manual, synchronization: manual or automatic (internal or line-lock), default, privacy zones, PAL/NTSC
<b>Activity detection</b>	yes
<b>Motion detector</b>	4 zones, ON/OFF switchable
<b>Privacy zones masking</b>	6 zones masking, ON/OFF switchable
<b>Serial interfaces</b>	RS-485
<b>Serial interfaces protocols</b>	Pelco D, Coaxitron
<b>External adjustments</b>	menu, zoom and focus
<b>External connections</b>	video (BNC), voltage input
<b>Mounting</b>	wall mount
<b>Temperature range (operation)</b>	-20°C ~+50°C
<b>Housing material</b>	aluminium
<b>Housing</b>	outdoor, bullet

# VKC-1379B/IR316

(Continuation Specifications)

Integrated wall mount	yes
Hidden cable management	yes
Sunshield	yes
Window heater	no
Clear Shield	no
Colour (housing)	Pantone 7541
Vandalism resistant	no
Protection rating	IP68
Alarm inputs	-
Alarm outputs	-
Supply voltage	12VDC, 24VAC, (+/-10%)
Power consumption	12W max.
Dimensions (HxWxD)	see drawing
Weight	2.0kg
Parts supplied	camera, sunshield, wall bracket, manual, bag of screws
Certificates	CE

## Optional accessories

70527	NE-132/AC24V	Power Supply Unit 230VAC/24VAC (1.0A)
70543	VT-PS12DC-10	Plugable AC/DC Adapter 100-240V/12VDC- 2.5A, stab., Cont. & UK Mains plug-ins
73179	PM-42	Pole Mount Adapter, for Housing Series Candid, W3 Plug&Play

# VKC-1379B/IR316

Home | Security | Cameras | Plug & Play

## Technical drawing

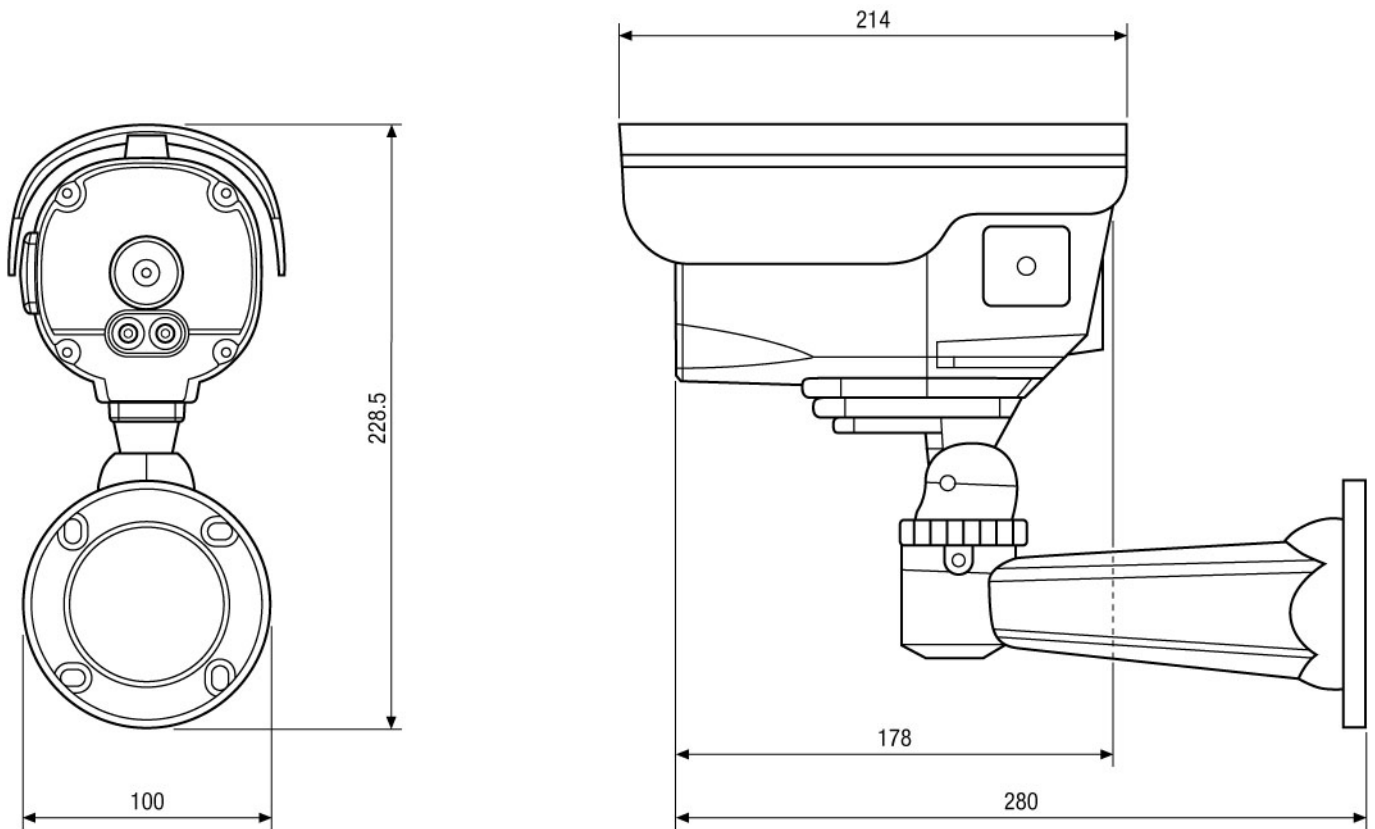

Maße/Dimensions: mm

SLD Security & Communications  
The Old Forge, Ockham Lane, Ockham, Surrey GU236PH England  
Phone +44.1483225633 · Fax +44.1483225634  
sales@sld.co.uk · www.sld.co.uk

