

VMC-19LCD-HMPG1

Home | Security | Monitors | TFT/LCD

VMC-19LCD-HMPG1
19" (48cm) LCD/TFT Professional Monitor,
1280x1024, 12VDC, Protection Glass

Art-Nr. 90559



Main Features

Professional PAL/NTSC LCD/TFT Monitor
Multiple Language On-Screen Menu Driven Set-up
3D Comb Filter
Resolution of 1280x1024 Pixels (SXGA) / 700TVL
CVBS, S-Video, HDMI, RGB and Audio Inputs
No Pixel Burn-in (Anti Burn Function)

Quick Signal Switching / Fast Response Time
Artifacts, Noise and Motion Blur Reduction
Compact Metal Cabinet with LCD Protection Glass
Integrated Loudspeakers
Protection Glass and IR Remote Control included
Options: Table Stand/Mounting Bracket, 19" Rack

Specifications

Video standard	PAL/NTSC
Display element	Colour TFT/LCD
Screen size	19"
Screen Size (cm)	48 cm
Pixel format	1280 (H) x 1024 (V) 0.294x0.294mm
Pixel fault class	ISO 13406-2, Class II
Scanning method	Digital progressive scan (Frame/Motion mode)
Resolution pixels	1280 x 1024
Resolution	CVBS and Y/C: 700TV lines; VGA: 640x480 (60 ~75Hz); SVGA: 800x600 (56 ~75Hz); XGA: 1024x768 (60 ~75Hz); SXGA: 1280x1024 (60 ~75Hz)

VMC-19LCD-HMPG1

(Continuation Specifications)

Comb Filter	The digital PAL 3D comb filter decoder offsets the preceding and succeeding images in order to achieve a better separation of the interwoven colour and black-and-white signals. Prevents colour streaks and uneven edges of colour
Colour scales	16.7Mio (8 Bit)
Contrast ratio typical	1000:1
Brightness typical	250 cd/m ²
Viewing angle vertical	160°
Viewing angle horizontal	160°
Light source	2CCFL
Response time typical	5 ms
PC interfaces	VGA, Analog RGB (0.714Vp-p, 75ohms), H & V sync. (TTL), 15-pin D-Sub
Video inputs (type)	CVBS, Y/C, VGA, HDMI
Video inputs	2x 1Vp-p, CVBS, automatic 75 ohms termination (loop-through), Y/C input, 4 pin Mini DIN, 75 ohms
Audio inputs	2
Audio input	Stereo (Cinch)
Audio output power	2x 0.5watts
Menu languages	English, German, French, Spanish, Italian, Polish, Czech, Russian
Supply voltage	12VDC (±0.5V)
Power consumption	28W
External adjustments	On-screen control, ON/OFF
Remote control	Wireless remote control enabled
Temperature range (Operation)	0 ~+40°C
Housing material	Aluminium
Mount	VESA standard (4 threads M4, 100x100mm)
Colour (housing)	anthracite
Dimensions (HxWxD)	362x419x54mm
Total height with stand	429mm
Weight	5.1kg
Parts supplied	PSU 100~240V/12VDC with power cord, VGA cable, IR remote control unit, Multiple language manual
Certificates	CE

Optional accessories

90468	VMC-LCD/WMB-4	Wall Bracket for LCD Monitors up to 23", Pan and Tilttable
90475	LCD-19P-RMK	19" Kit for 19" LCD Monitor (VMC-19LCD-P and VMC-19LCD-HMC1)
90449	VMC-LCD/CMB-1	Ceiling Mount Bracket, Pan and Tilttable for LCD Monitors 19" to 30"
90394	VMC-LCD/WCMB-1	Wall/Ceiling Bracket for LCD Monitors 15"/17"/19"/P/CP/CM/HPC/HMC1 Series

VMC-19LCD-HMPG1

90553	LCD-ST/HM	Desktop Mount for LCD Monitor VMC-15/17/19, LCD/HMC Series
90505	UNO	Wall Bracket for LCD Monitors up to 23", Pan and Tilttable

VMC-19LCD-HMPG1

Home | Security | Monitors | TFT/LCD

Technical drawing

19"-Einbaukit /
19" Rack mount kit

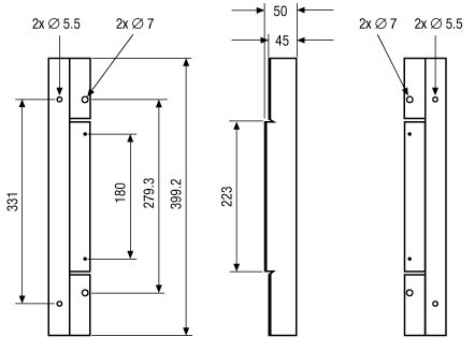
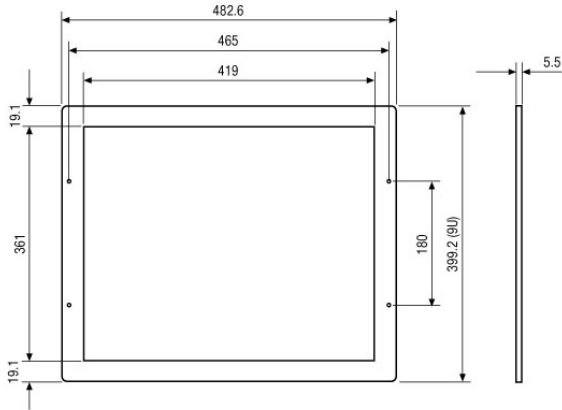

Tischstandfuß / Desktop mount

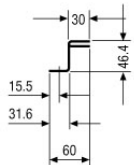
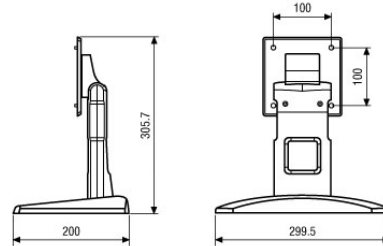

Wandhalterung für 15-19" LCD-Monitore /
Wall bracket for LCD monitors, 15-19"

VMC-LCD/WMB-4

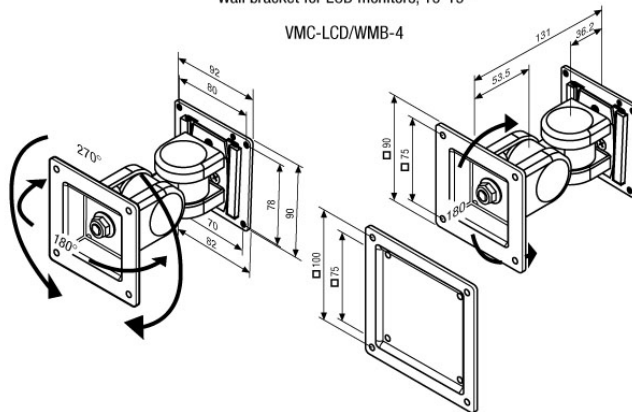

Maße/Dimensions: mm

SLD Security & Communications
The Old Forge, Ockham Lane, Ockham, Surrey GU236PH England
Phone +44.1483225633 · Fax +44.1483225634
sales@sld.co.uk · www.sld.co.uk

SLD Security &
Communications

