

# EKR-KB1

Home | Security | Processing | Accessories

EKR-KB1

Universal Keyboard for Matrix Switchers EKR Series,

Pantone Coolgray 1C

Art-Nr. 75207



## Main Features

Operation of EKR-(8)16/4 , EKR-32/8 Matrixes  
Fixed or Variable Speed Control  
Camera and Monitor Call-Up  
Programmable Sequences/Salvos and Tours  
LCD Display

Addressable  
RS-485 Serial Interface  
Supply Voltage: 12VDC  
Direct Control of P/T Head and Domr Cameras

## Specifications

Colour	white
Weight	1.7kg
Supply voltage	12VDC (Power supply 100-240VAC included)
Joystick	3-axis proportional joystick for manual control of variable speed
Direct mode	Via RS-485, RJ-11 interface for the P/T head series VPT-41/-42 and for Dome cameras from eneo, Pelco, Elbex, Ernitec, Elmo, JVC, Panasonic, Samsung, Santec, Sensormatic, Star, VCL, and others
Macro function	Up to 10 free configurable virtual keys for macro functions
Control functions	Keys select cameras and monitors, operate presets, patterns, auxiliaries, and sequences Camera functions: pan, tilt, zoom, focus, iris for fixed or variable speed control of pan and tilt heads and dome cameras
PC interfaces	RS-232 for firmware update
Control Interface	1x RS-485 for Matrix and Multiplexer control. 2x RS-485 for independent daisy-chain control of up to 999 telemetry receivers each, via 1200m max. distance

# EKR-KB1

(Continuation Specifications)

<b>Menu languages</b>	English, German, French, Italian
<b>Backup</b>	Set-up and firmware update via RS-232 Interface (Distance of up to 15m max.)
<b>Password protection</b>	3 password levels: connection, set-up, alarm reset
<b>Housing</b>	Thermo-resistant and shock proof ABS plastic
<b>Parts supplied</b>	Wide range power supply, Power and RJ-11 cables, RJ-11 shunt box, German/English manual (other languages upon request)
<b>Certificates</b>	CE

# EKR-KB1

Home | Security | Processing | Accessories

## Technical drawing

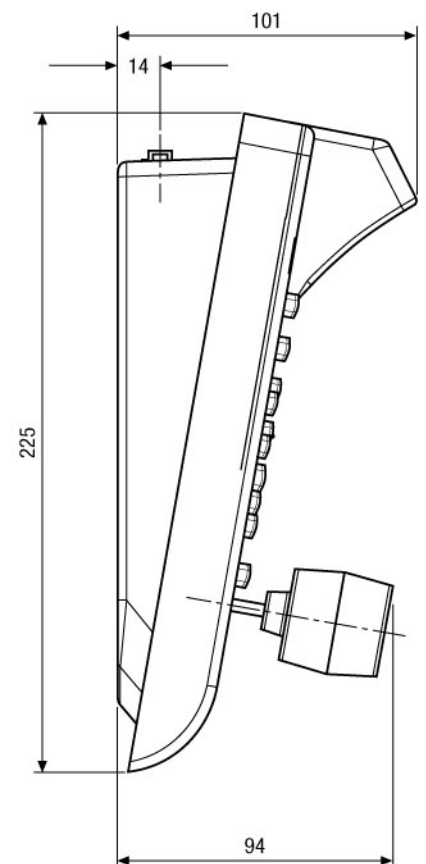
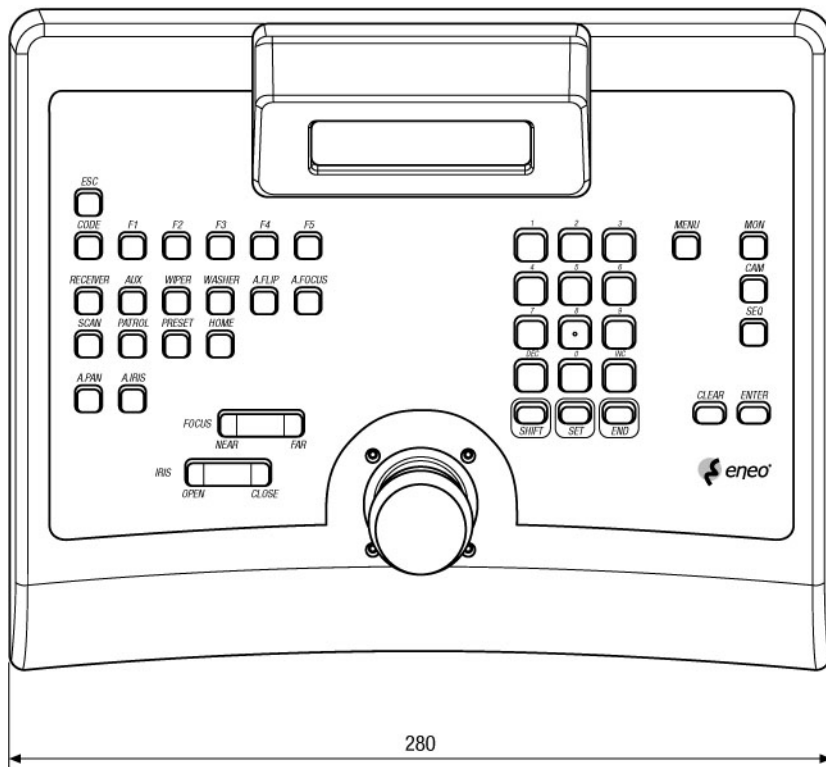
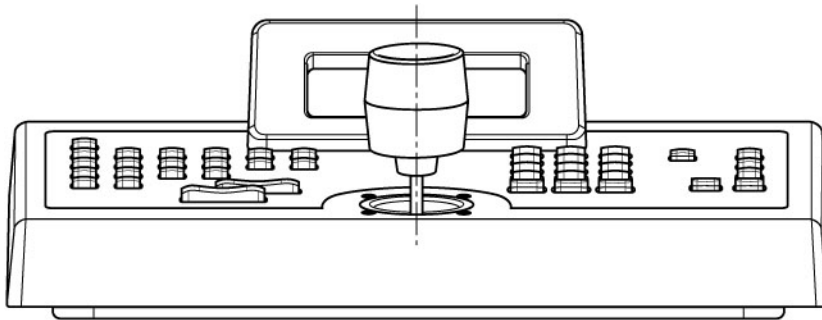

SLD Security & Communications  
The Old Forge, Ockham Lane, Ockham, Surrey GU236PH England  
Phone +44.1483225633 · Fax +44.1483225634  
sales@sld.co.uk · www.sld.co.uk

SLD Security & Communications

